

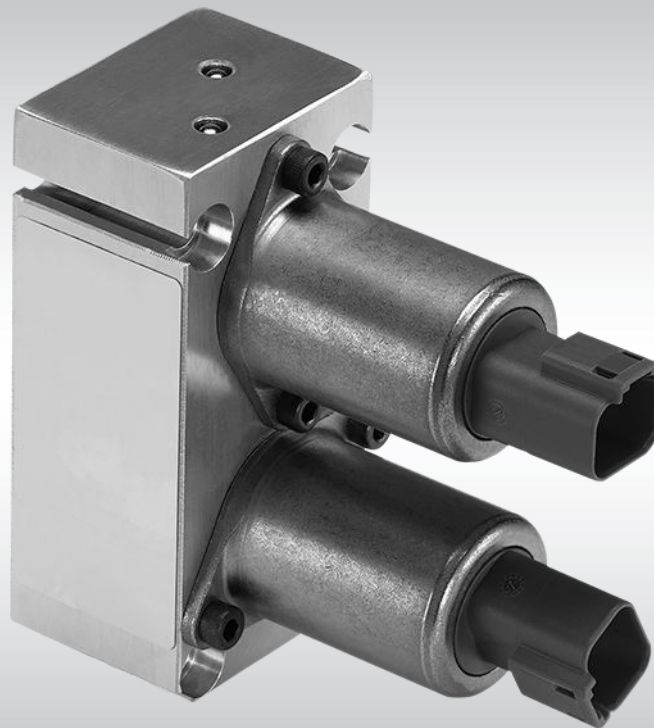

Technical Information

# Electro-hydraulic Actuator PVHC



**Revision history***Table of revisions*

<b>Date</b>	<b>Changed</b>	<b>Rev</b>
May 2014	Converted to Danfoss layout – DITA CMS	AE
July 2013	PVHC code numbers changed, pages reduced to 8.	AD
December 2010	New back cover	AC
April 2010	Japan location	AB
April 2009	First edition	AA

**Contents****General Information**

Introduction.....	4
Function.....	4
Hydraulic Actuation.....	4
Features.....	4

**Technical Data**

Technical data input - output relation.....	5
Performance Graphs.....	6

**Connections**

Deutsch connector.....	7
AMP connector.....	7
PVHC code numbers for use on PVG 32 / 100.....	7

**Dimensions**

## General Information

### Introduction

The PVHC is an electrical actuator module for main spool control in PVG 32 and PVG 100.

The actuator uses two current controlled proportional pressure-reducing valves.

PVHC does not use the known PVE internal closed loop control technology, and does therefore not offer any kind of fault monitoring system, neither active nor passive.

### Function

With electrical proportional actuation, the main spool position is adjusted so that its position corresponds to an electrical control signal.

The control signal is converted into a hydraulic pressure signal that moves the main spool in the PVG.

This is done by means of two proportional pressure-reducing valves.

The electrical actuator can be controlled either by a current amplifier card, or directly from a programmable micro-controller.

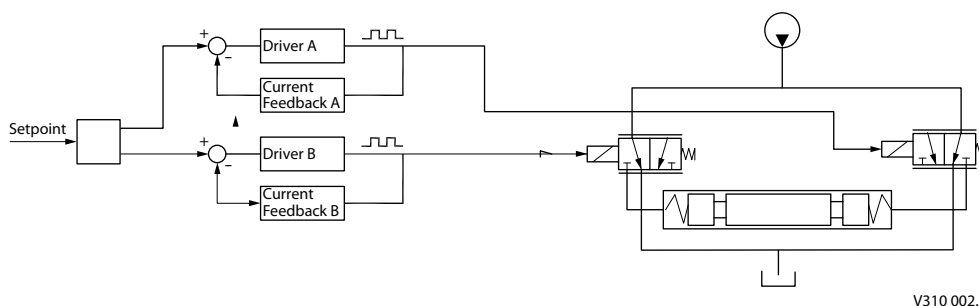

### Hydraulic Actuation

It is necessary to use the PVHC in combination with 25 bar [362.6 psi] pilot pressure, and standard FC spools fitted for hydraulic actuation. See PVG 32 Technical Information 520L0344 and PVG 100 Technical Information 520L0720.

Because of the 25 bar pilot pressure, it is not possible to combine PVHC with PVE on a PVG 32 or PVG 100 valve stack.

### Features

- PWM current control signals.
- AMP JPT and Deutsch DT connector options.
- 12 V or 24 V supply options.
- Only to be used with 25 bar pilot pressure and hydraulic main spool.
- Possible to option mount the PVHC on PVG 32 and PVG 100.

#### **Warning**

All makes and all types of directional control valves – including proportional valves – can fail and cause serious damage. It is therefore important to analyse all aspects of the application. Because the proportional valves are used in many different operation conditions and applications, the manufacturer of the application is responsible for making the final selection of the products – and assuring that all performance, safety and warning requirements of the application are met. The process of choosing the control system – and safety level – could e.g. be governed by ISO 13849 (Safety related parts of control system).

---

**Technical Information PVHC Electro-hydraulic Actuator for use on PVG 32 and PVG 100**

---

**Technical Data**
**Technical data input - output relation**
*Temperature*

	Temperature range
Ambient	-30°C to 80°C [-22 °F to 176°F]
Medium	-20°C to 80°C [-4 °F to 176°F]

*Input control*

Parameter	Control range	
	12 V	24 V
Controller output current range	0 - 1500 mA	0 - 750 mA
Pressure control range	5 to 15 bar [72.5 to 217.5 psi]	
Resistance	4.75 Ω ± 5%	20.8 Ω ± 5%

*Enclosure*

Connector type	Protection class
Deutsch DT	IP 67
AMP JPT 12/24 V	IP 66

*Filtering*

Filtering in the hydraulic system	Max. permissible degree of contamination (ISO 4406, 1999 version): 23/19/16
-----------------------------------	---

*Oil viscosity*

Oil viscosity	Range: 12 - 75 mm <sup>2</sup> /s [65 - 350 SUS] Min.: 4 mm <sup>2</sup> /s [40 SUS] Max.: 460 mm <sup>2</sup> /s [2130 SUS]
---------------	--

*Pilot pressure*

Pilot pressure (over tank)*	Nom: 25 bar [363 psi] Min: 21 bar [305 psi] Max: 25 bar [363 psi]
-----------------------------	---

\* Designed to be used with hydraulic activated spools.

Technical Data

Performance Graphs

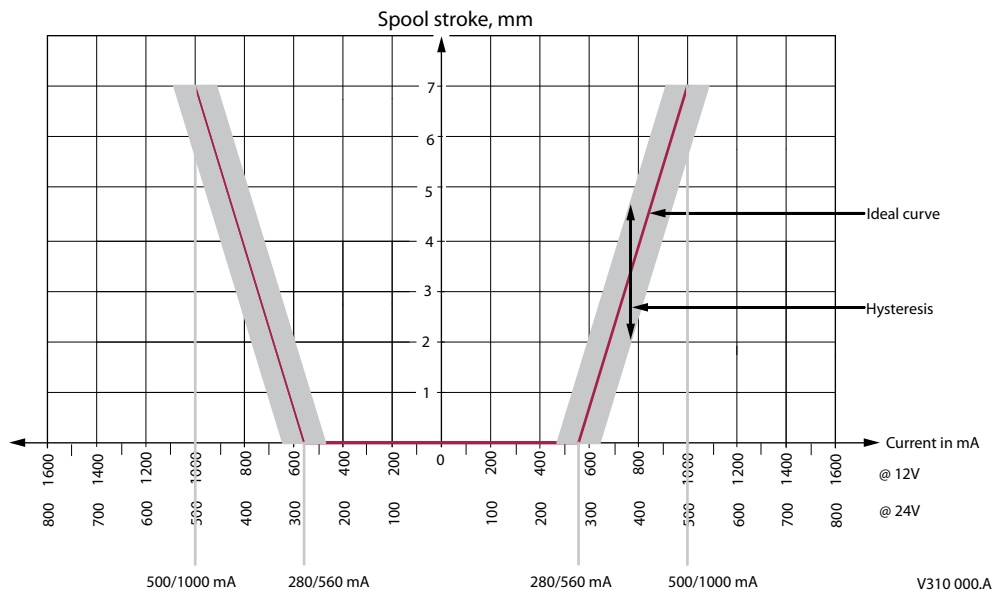
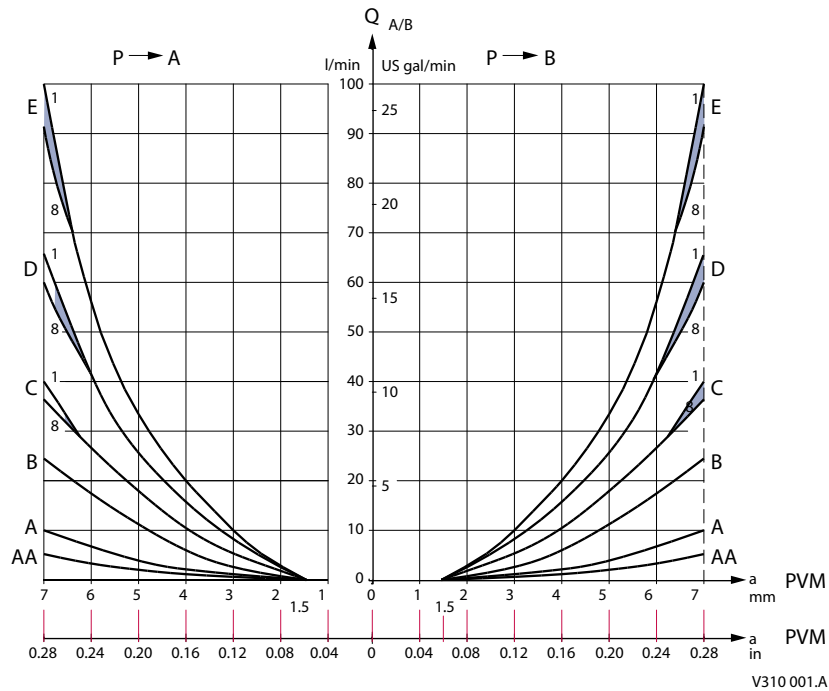

The ideal curve is determined by the main spool neutral spring. The hysteresis is affected by viscosity, friction, flow forces, dither frequency and modulation frequency.

The PVHC is produced in an environment using mineral based hydraulic oil.

**Technical Information PVHC Electro-hydraulic Actuator for use on PVG 32 and PVG 100**

**Connections**

**Deutsch connector**

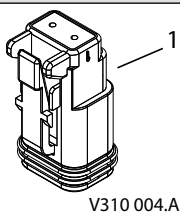
Pos. 1	Description	Qty	Deutsch code numbers
 V310 004.A	Housing	1	DT06-2S
	Lock Part	1	W2S
	Pin Contact	2	0462-201-16141 when SOC 16-18 AWG*
		2	0462-209-16141 when SOC 14-16 AWG*

**AMP connector**

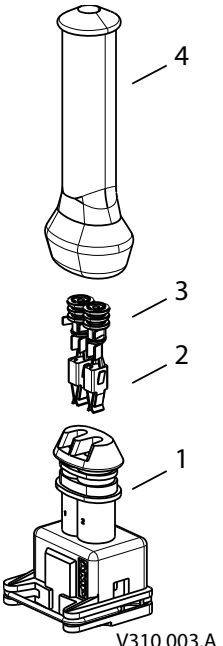
Pos.	Exploded view	Description	Qty	AMP code numbers
1	 V310 003.A	Connector	1	282189-1
2		Contacts	2	929930-3
3		Contacts	2	828905-1
4		Superséal	1	880810-1

**PVHC code numbers for use on PVG 32 / 100**

*PVHC, High Current PWM Actuator*

	Code No. (12 V)	Code No. (24 V)
Amp. connector	11112037	11112036
Deutsch connector	11112038	11112039

**Dimensions**

*Dimensions for AMP connector*

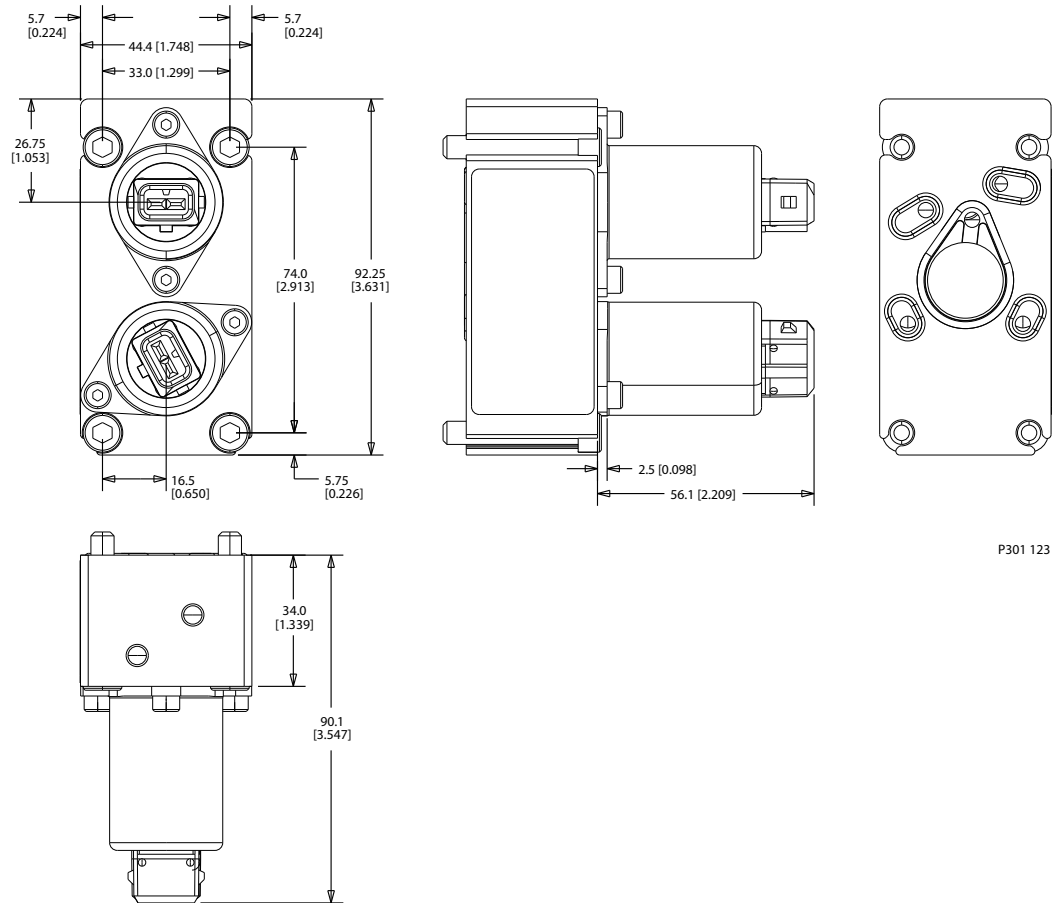

P301 123



**Dimensions**

*Dimensions for Deutsch connector*

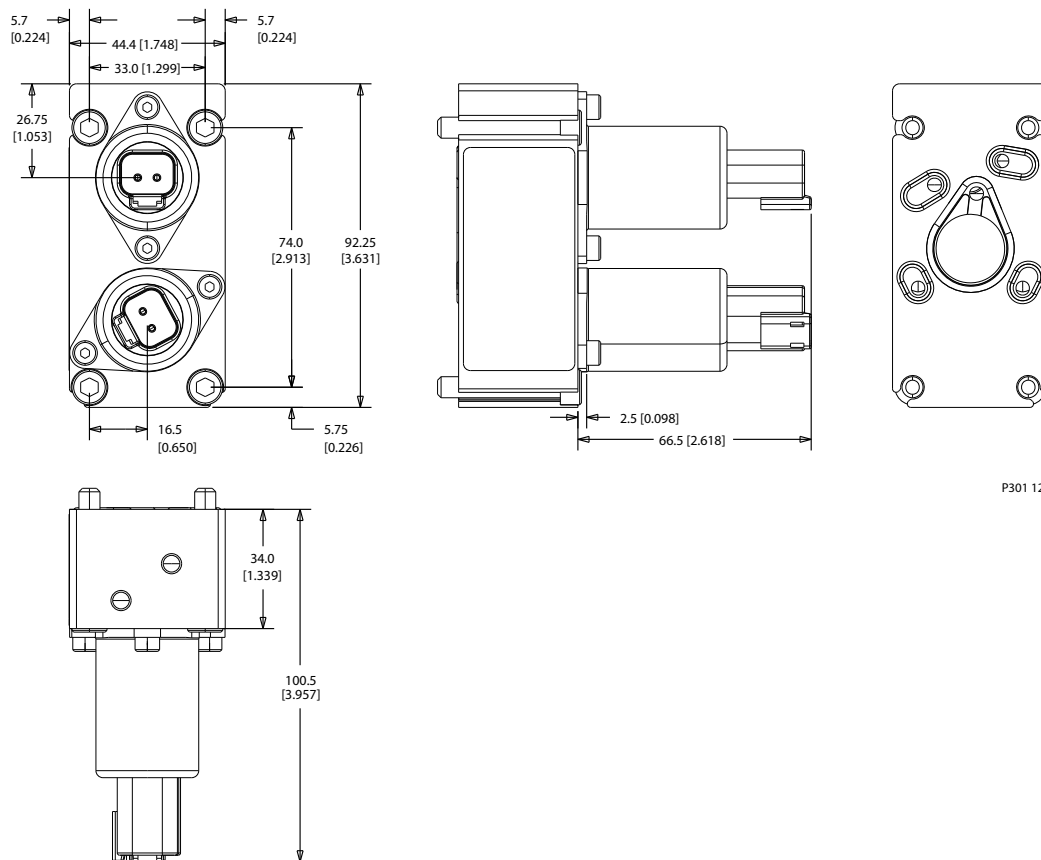

P301 124







#### Products we offer:

- Bent Axis Motors
- Closed Circuit Axial Piston Pumps and Motors
- Displays
- Electrohydraulic Power Steering
- Electrohydraulics
- Hydraulic Power Steering
- Integrated Systems
- Joysticks and Control Handles
- Microcontrollers and Software
- Open Circuit Axial Piston Pumps
- Orbital Motors
- PLUS+1® GUIDE
- Proportional Valves
- Sensors
- Steering
- Transit Mixer Drives

**Danfoss Power Solutions** is a global manufacturer and supplier of high-quality hydraulic and electronic components. We specialize in providing state-of-the-art technology and solutions that excel in the harsh operating conditions of the mobile off-highway market. Building on our extensive applications expertise, we work closely with our customers to ensure exceptional performance for a broad range of off-highway vehicles.

We help OEMs around the world speed up system development, reduce costs and bring vehicles to market faster.

Danfoss – Your Strongest Partner in Mobile Hydraulics.

**Go to [www.powersolutions.danfoss.com](http://www.powersolutions.danfoss.com) for further product information.**

Wherever off-highway vehicles are at work, so is Danfoss.

We offer expert worldwide support for our customers, ensuring the best possible solutions for outstanding performance. And with an extensive network of Global Service Partners, we also provide comprehensive global service for all of our components.

Please contact the Danfoss Power Solution representative nearest you.

#### Comatrol

[www.comatrol.com](http://www.comatrol.com)

#### Schwarzmueller-Inverter

[www.schwarzmueller-inverter.com](http://www.schwarzmueller-inverter.com)

#### Turolla

[www.turollaocg.com](http://www.turollaocg.com)

#### Valmova

[www.valmova.com](http://www.valmova.com)

#### Hydro-Gear

[www.hydro-gear.com](http://www.hydro-gear.com)

#### Daikin-Sauer-Danfoss

[www.daikin-sauer-danfoss.com](http://www.daikin-sauer-danfoss.com)

Local address:

**Danfoss Power Solutions US Company**  
2800 East 13th Street  
Ames, IA 50010, USA  
Phone: +1 515 239 6000

**Danfoss Power Solutions GmbH & Co. OHG**  
Krokamp 35  
D-24539 Neumünster, Germany  
Phone: +49 4321 871 0

**Danfoss Power Solutions ApS**  
Nordborgvej 81  
DK-6430 Nordborg, Denmark  
Phone: +45 7488 2222

**Danfoss Power Solutions (Shanghai) Co., Ltd.**  
Building #22, No. 1000 Jin Hai Rd  
Jin Qiao, Pudong New District  
Shanghai, China 201206  
Phone: +86 21 3418 5200

Danfoss can accept no responsibility for possible errors in catalogues, brochures and other printed material. Danfoss reserves the right to alter its products without notice. This also applies to products already on order provided that such alterations can be made without changes being necessary in specifications already agreed.. All trademarks in this material are property of the respective companies. Danfoss and the Danfoss logotype are trademarks of Danfoss A/S. All rights reserved.